



# VERTICAL MILL

VM 11, VM 15, VM 18,5, VM 22

Vertical (hammer) mill made by our company TAURUS, s.r.o., Chrudim is the machine for milling of cereals determined. Material is milled by beaters in a high speed rotated as well as by friction between cover of sieve and raw materials.

The machine is determined for montage in technologic plants, where is made the fodder mixtures for animals. There are such equipment as a silo for raw material and silo for milled material, also conveyers and the machines for processing of loose materials, in these plants.

The mill is possible to use also for milling of bones in rendering plants, for milling of wooden wastes in wooden industry and some lumpy raw materials in various industrial plants.

### Advantages:

- saving and reliable operation
- minimal maintenance
- easy Exchange of sieves
- easy operation
- easy cleaning of the machine
- long service life of the rotor and hammers

### The possibility of grinding:

- cereals and frains for feed
- wood chips and wood waste
- straw
- residues of bricks
- bones (rendering plant)
- lumpy materials
- waste



Data		Unit	Model							
			VM 11		VM 15		VM 18,5		VM 22	
Basic dimensions	length	mm	1000		1000		1000		1000	
	width		1000		1000		1000		1000	
	height		1727		1742		1780		1800	
Weight	total	kg	400		410		425		470	
	drive		105		111		132		165	
	rotor		19,5		19,5		19,5		20,6	
Type of drive		-	160 M		160 M		160 L		180 M	
Installed output		kW	11		15		18,5		22	
Specific current		A	21,4		28,2		32,5		40,5	
Specific RPM		rpm	2910		2925		2940		2940	
Rotor diameter		mm	620							
Number of hammers		pcs	16							
Sieve inlet diameter		mm	2	2,5	3	3,5	4	5	6	8
Efficiency (for wheat Ø3-4 mm sieve)		t/h	1,5-2,0		2,0 – 3,0		2,5 – 3,5		3,2-4,0	



## Basic dimensions

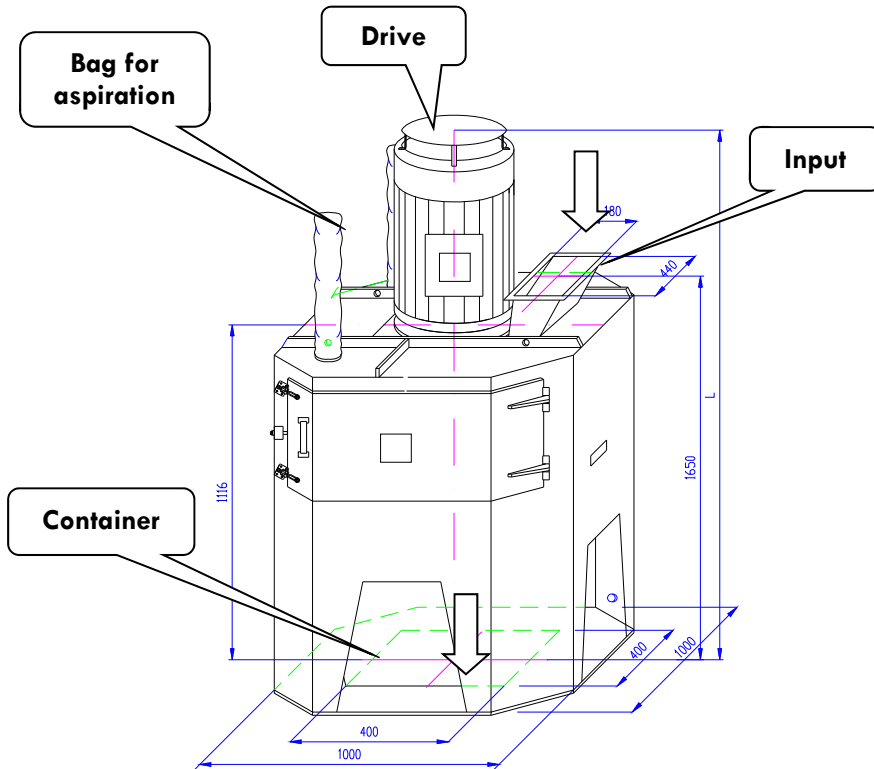

Rozměr Typ	L (mm)
VM 11	1730
VM 15	1730
VM 18,5	1730
VM 22	1800
VM 30	1930

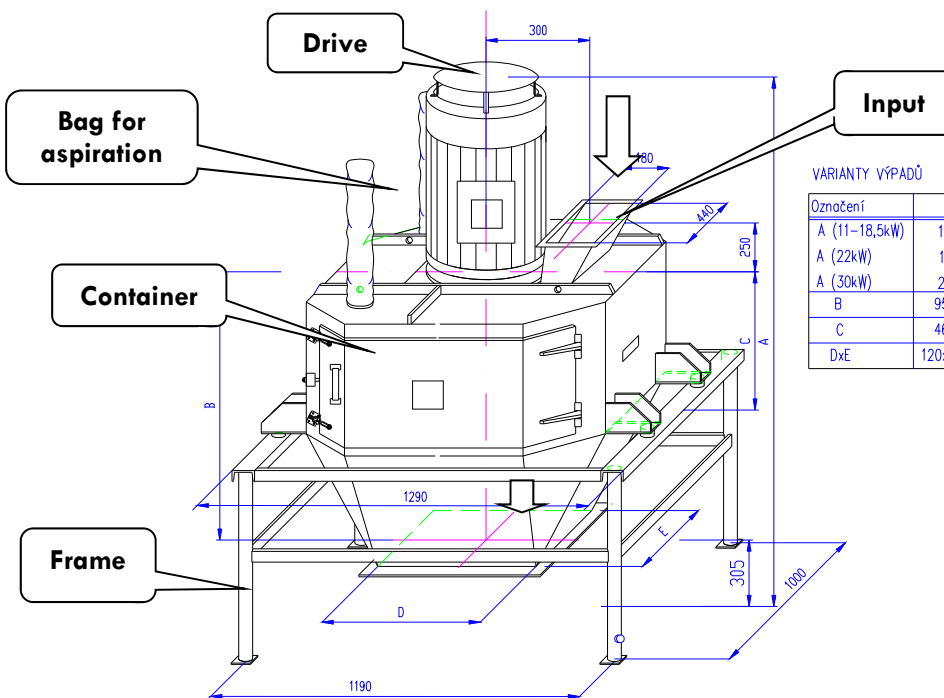

VARIANTY VÝPADŮ

Označení	Rozměr (mm)			
A (11-18,5kW)	1794	1834	1794	1794
A (22kW)	1913	1953	1913	1913
A (30kW)	2040	2080	2040	2040
B	958	998	958	958
C	465	505	465	465
DxE	120x120	152x152	220x220	400x400