



SCREW TUBE CONVEYOR

TŠ 60, 100, 130, 150, 200, 250, 300, 350, 400

Screw Tube Conveyor TŠ produced by TAURUS, s.r.o., Chrudim, is a machine designed for transport of bulk non-abrasive materials. The material is transported by means of a helix welded to a central shaft rotating in a worm gear box in the shape of a tube.

The Machine is designed for integration into technological units for preparation of compound feedingstuffs for animals and similar industrial operations consisting of storage equipment and connected technological equipment for processing of bulk materials.

Various surface treatments are on offer: varnish (synthetic), hot dip galvanizing, stainless steel.

Advantages:

- Economical and reliable operation
- Minimum maintenance demands
- Any length according to the customer's requirement
- Sloping transport of materials - tilt up to 60°
- Low energy demands and economic demands

Transported material:

- Cereals and corn meals
- Cement and concrete mix
- Coal and ash
- Waste, sludges, and plastics
- Salt, spices, and feedingstuffs



Item	Unit	TŠ version								
		TŠ 60	TŠ 100	TŠ 130	TŠ 150	TŠ 200	TŠ 250	TŠ 300	TŠ 350	TŠ 400
Worm diameter		60	100	130	150	200	250	300	350	400
Length max.	mm	10	10	15	20	20	20	20	20	20
Machine height		000	000	000	000	000	000	000	000	000
Weight without drive	kg/m	8.6	9.8	12.8	20	24	27	32	42	55
Rated supply voltage	V	230/400								
Rated frequency	Hz	50								
The lowest degree of electrical equipment protection	-	IP 54								
Installed power (according to length and capacity)	kW	0.37 - 1.1	0.55 - 1.5	0.75 - 3	0.75 - 3	1.1 - 4	1.1 - 5.5	2.2 - 7.5	2.2 - 11	2.2 - 11
Capacity	m ³ /h	1	4	7	11	21	35	45	60	80
Basic machine speed	rpm	200	200	150	150	120	120	80	80	60



Basic Dimensions of the Machine

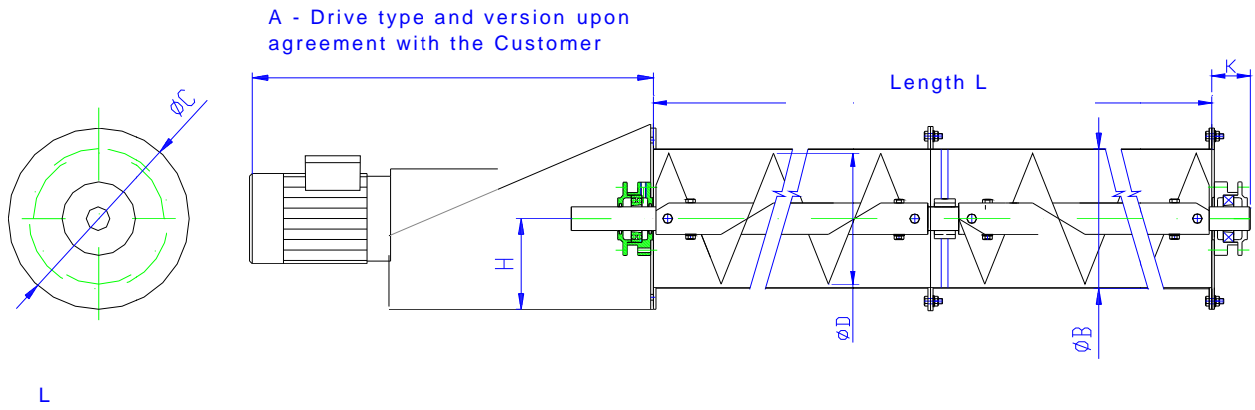

Dimensions /mm/	A	B	C	D	H	K
TŠ 60	-	76	130	60	80	50
TŠ 100	-	114	185	100	110	55
TŠ 130	-	152	215	130	135	55
TŠ 150	-	170	235	150	180	55
TŠ 200	-	220	285	200	155	65
TŠ 250	-	270	335	250	170	65
TŠ 300	-	320	410	300	210	70
TŠ 350	-	380	460	350	230	70
TŠ 400	-	420	500	400	250	70